

# Palm Beach State College

## REQUEST FOR QUOTE

RFQ #11/12-06

RFQ Title: Theatre Lighting

Date: December 7, 2011

To: All Submitters

From: Purchasing Manager

You are invited to submit sealed quotes subject to the terms, conditions, and specifications contained herein and are hereby made part of this request.

- All quotes must be executed and submitted in a sealed envelope.
- Faxed quotes will not be accepted.
- The face of the envelope shall state "Request for Quote #11/12-06"
  - the quote name
  - the company name
  - delivered to:

**Purchasing**

Palm Beach State College  
4200 Congress Avenue, MS #27  
Lake Worth, FL 33461

- All quotes must be received at the address above no later than 3:00 PM.
- Quotes will be opened publicly at that time.
- Quotes received after this date and time will be rejected.
- Quotes will not be evaluated at this time.
- The evaluation date and time is noted in the RFQ document.

With the consent and agreement of the successful quoter, purchases may be made under this RFQ by other community colleges, state universities, district school boards, and by other Florida public entities. Such purchases shall be governed by the same terms and conditions stated in the proposal solicitation as provided in State Board of Education Rule 6A-14.0734 (2) (d).

Quoters shall note exceptions to the above paragraph, if any.

In order to insure uniformity, all quotes must be submitted on the enclosed forms or exact photo copies and signed by an authorized representative of the company submitting the proposal. Quotes not submitted in accordance with the terms, conditions, specifications, and other instructions contained herein may be subject to rejection.

Direct all inquiries regarding this Request for Quotes (RFQ) to the Purchasing department, in writing, by e-mail:  
[purchasing@palmbeachstate.edu](mailto:purchasing@palmbeachstate.edu)

All inquiries, with responses, will be made available to all vendors on an equal basis without prejudice.

**TABLE OF CONTENTS**

**SECTION A: GENERAL CONDITIONS ..... 3-6**

1. STANDARD TERMS AND CONDITIONS ..... 6

**SECTION B: SCOPE OF SERVICES AND REQUIREMENTS ..... 7**

1. PROJECT SUMMARY ..... 7

2. SCHEDULE ..... 7

3. CONTRACT TERM..... 7

4. STATEMENT OF WORK ..... 7

**SECTION C: INSTRUCTIONS AND INFORMATION ..... 8**

1. PROCESS FOR SUBMITTING QUOTES ..... 8

2. EVALUATION CRITERIA ..... 8-9

**APPENDIX A: SUBMISSION RESPONSE FORM ..... 10**

**APPENDIX B: PROJECT SPECIFIC BACKGROUND ..... 11**

1. PRODUCT SPECIFICATION..... 11A-11B

**APPENDIX C: FORM FOR SUBMITTING QUESTIONS ..... 12**

**APPENDIX D: FORM FOR SUBMITTING NO BID ..... 13**

# Section A

## GENERAL CONDITIONS

**To insure acceptance of the bid, follow these instructions:**

<p><b>SEALED QUOTES:</b> All quote sheets and forms must be executed and submitted in a sealed envelope. Do not include more than one quote per envelope. Quotes not submitted on the attached form shall be rejected. All quotes are subject to the conditions specified herein. Those which do not comply with these conditions are subject to rejection. It is the sole responsibility of the quoter to deliver the quote to the address contained herein on, or before, the closing hour and date indicated. The College is not responsible for delays with postal delivery nor the normal delay in delivery for internal mail procedures. Palm Beach State College will not be responsible for the inadvertent opening of a quote not properly sealed, addressed or identified.</p>	<p><b>DEFINITIONS:</b> [College] refers to Palm Beach State College. [Quoter] refers to the dealer, manufacturer, contractor, or business organization submitting a quote to the College in response to this request for quote. [Vendor] refers to the dealer, manufacturer, contractor, or business organization that will be awarded a contract pursuant to the terms, conditions and quotations of the quote. [Quoter] and [Vendor] will be used interchangeably. [Quoter] and [Bidder] may be used interchangeably throughout this document. [Quote] and [Bid] may be used interchangeably throughout this document.</p>
<p><b>EXECUTION OF QUOTE:</b> Quotes must contain a manual signature of an authorized representative in the space provided on the quote submittal form. Quote must be typed or printed in ink. No erasures are permitted. If a correction is necessary, draw a single line through the entered figure and enter the correct figure above it. Corrections must be initialed by the person signing the quote. Any illegible entries, pencil quotes or corrections not initialed will not be tabulated.</p>	<p><b>QUOTE OPENING:</b> Shall be public, at the address indicated on the RFQ document, on the date and at the time specified on the quote form. Quotes will not be evaluated nor will questions be fielded at the time of opening. The quote opening is to determine the vendor pool only. It is the quoter's responsibility to assure that the quote is delivered at the proper time and place of the opening. Quotes received after the date and time will be retained, unopened, for the record. Quotes by fax, email or telephone will not be accepted.</p>
<p><b>PRICES, TERMS and PAYMENT:</b> Firm prices shall be quoted, typed or printed in ink, and includes all packaging, handling, shipping charges and delivery to the destination shown herein.</p>	<p><b>NO BID:</b> If not submitting a quote, respond by returning the quote submission form, marking it "NO BID", and explain the reason.</p>
<p><b>EVALUATION OF QUOTES:</b> The evaluation committee intends to recommend to Palm Beach State College Board of Trustees to authorize College administration to award a contract with the quoter, or quoters, scoring the overall highest evaluation points.</p>	<p><b>CONDITION AND PACKAGING:</b> It is understood and agreed that any item offered or shipped as a result of this quote shall be the new, current model in production available at the time of this quote. All containers shall be suitable for storage or shipment, and all prices shall include standard commercial packaging.</p>
<p><b>AWARDS:</b> In the best interest of the College, the College reserves the right to make award(s) by individual item, group of items, all or none or a combination thereof; to reject any and all quotes or waive any minor irregularity or technicality in quotes received. The College also reserves the right to make awards to one, or more, vendors based upon the recommendations of the evaluation committee.</p>	<p><b>TAXES:</b> The College does not pay sales taxes on direct purchases of tangible personal property. Do not include these items on invoices. See exemption number on face of purchase order. Exemption does not apply to purchases of tangible personal property made by contractors who use the tangible personal property in the performance of contracts for the improvement of state owned real property as defined in Chapter 192 F.S.</p>
<p><b>DISCOUNTS:</b> Quoters are encouraged to reflect cash discounts in unit prices quoted. Quoters may offer a cash discount for prompt payment; however, discounts for less than 30 days will not be considered in determining the lowest net cost for quote evaluation purposes. Discount time will be computed from the date of satisfactory delivery at place of acceptance or from receipt of correct invoice at the office specified, whichever is later.</p>	<p><b>MISTAKES:</b> Quoters are expected to examine the specifications, delivery schedule, quote prices, extensions, and all instructions pertaining to supplies and services. Failure to do so will be at the quoter's risk. In case of mistake in extension, the unit price will govern.</p>
<p><b>CLARIFICATION/CORRECTION OF BID ENTRY:</b> The College reserves the right to allow for the clarification of questionable entries and for the correction of obvious mistakes.</p>	<p><b>COSTS:</b> The College is not liable for any costs incurred by a quoter in responding to this RFQ, including those for presentations, when applicable.</p>
<p><b>SAFETY STANDARDS:</b> Unless otherwise stipulated in the quote, all manufactured items and fabricated assemblies shall comply with applicable requirements of Occupational Safety and Health Act and any standards there under. Failure to comply with the condition will be considered as a breach of contract.</p>	<p><b>UNDERWRITERS' LABORATORIES:</b> Unless otherwise stipulated in the quote, all manufactured items and fabricated assemblies shall carry U.L. approval and reexamination listing where such has been established.</p>

<p><b>PAYMENT:</b> Payment will be made by the College after the items awarded to a vendor have been received, inspected, and found to comply with award specifications, be free of damage /defect and properly invoiced. All invoices shall bear the purchase order number. Payment for partial shipments shall not be made unless specified in the quote. An original invoice should be submitted. Failure to follow these instructions may result in a delay in processing invoices for payment. In addition, the purchase order number should appear on bills of lading, packages, cases, delivery lists and correspondence.</p>	<p><b>FREIGHT TERMS:</b> All goods will be delivered F.O.B. Palm Beach State College Central Receiving 4200 Congress Avenue Lake Worth, FL 33461 Unless otherwise specified</p>
<p><b>DELIVERY:</b> Unless actual date of delivery is specified (or if specified delivery cannot be met), show number of days required to make delivery after receipt of purchase order. Delivery time may become a basis for making an award. Delivery shall be within the normal working hours of the user, Monday through Friday, unless otherwise specified.</p>	<p><b>INTERPRETATIONS:</b> Any questions concerning conditions and specifications shall be directed in writing to Palm Beach State College Purchasing office for receipt no later than seven(7) business days prior to the RFQ opening. Inquiries must reference the date of RFQ opening and RFQ number</p>
<p><b>ADDITIONAL QUANTITIES:</b> The College reserves the right to acquire additional quantities at the prices quoted in this invitation. If additional quantities are not acceptable, the quote sheets must note: <b>For Specified Quantity Only.</b></p>	<p><b>CONFLICT OF INTEREST:</b> The award hereunder is subject to the provisions of Chapter 112, Florida Statutes. All quoters must disclose with their quote the name of any officer, director, or agent who is also an employee or relative of the Palm Beach State College. Further, all quoters must disclose the name of any employee or family member thereof, who owns, directly or indirectly, an interest in the quoter's firm or any of its branches. The quoter shall not compensate, in any manner, directly or indirectly, any officer, agent, or employee of the College for any act or service that he/she may do, or perform for, or on behalf of any officer, agent or employee of the quoter. No officer, agent, or employee of the College shall have any interest, directly or indirectly, in any contract or purchase made, or authorized to be made by anyone for, or on behalf of the College. The quoter shall have no interest and shall not acquire any interest that shall conflict in any manner or degree with the performance of the services required under this RFQ.</p>
<p><b>NONCONFORMANCE TO CONTRACT CONDITIONS:</b> Items may be tested for compliance with specifications by appropriate testing laboratories. The data derived from any tests for compliance with specifications are public records and open to examination thereto in accordance with Chapter 119, Florida Statutes. Items delivered not conforming to specifications may be rejected and returned at vendor's expense. These items and items not delivered as per delivery date in RFQ and/or purchase order may result in quoter being found in default in which event any and all procurement costs may be charged against the defaulting contractor. Any violation of these stipulations may also result in the supplier's name being removed from the vendor pool.</p>	<p><b>SERVICE AND WARRANTY:</b> Unless otherwise specified, the quoter shall define any warranty service and replacements that will be provided during and subsequent to performance of this contract. Quoters must explain on an attached sheet to what extent warranty and service facilities are provided</p>
<p><b>PURCHASES BY OTHER ENTITIES:</b> With the consent and agreement of the successful bidder(s), purchases may be made under this bid by other colleges, universities, school boards, political subdivisions, or state agencies. Such purchases shall be governed by the same terms and conditions stated in the bid/quote solicitation as provided in State Board of Education Rule 6A-14.0734(2)(d).</p>	<p><b>SAMPLES:</b> Samples of items, when required, must be furnished free of expense, on or before RFQ opening time and date, and if not destroyed by testing may, upon request, be returned at the quoter's expense. Each individual sample must be labeled with the quoter's name, manufacturer's brand name and number, RFQ number and item reference. Request for return of samples shall be accompanied by instructions which include shipping authorization and name of carrier and must be received with your quote. If return instructions are not received with the quote, the commodities shall be disposed of by the College.</p>
<p><b>GOVERNMENTAL RESTRICTIONS:</b> In the event any governmental restrictions may be imposed that necessitate alteration of material, quality, workmanship or performance of the items offered on this quote prior to their delivery, it shall be the responsibility of the successful quoter to notify the College at once, indicating in their letter the specific regulation which required an alteration. The College reserves the right to accept or reject any such alteration, including any price adjustments occasioned thereby, or to cancel the contract at no expense to the College.</p>	<p><b>PUBLIC RECORD LAW:</b>Any material submitted in response to this RFQ will become a public document pursuant to Section 119.07, F.S. This includes material which the responding quoter might consider to be confidential or a trade secret. Any claim of confidentiality is waived upon submission, effective after opening pursuant to Section 119.07, Contractor's refusal to comply with this provision shall constitute sufficient cause for termination of the contract resulting from this RFQ.</p>
<p><b>LIABILITY:</b> The supplier shall hold harmless the College, its officers, agents and employees from liability of any kind in the performance of this contract.</p>	<p><b>LEGAL REQUIREMENTS:</b> Applicable provision of all Federal, State, county and local laws, and of all ordinances, rules, and regulations shall govern development submittal and evaluation of all quotes received in response hereto and shall govern any and all claims and disputes which may arise between person(s) submitting a RFQ response hereto and the College by and through its officers, employees and authorized representatives, or any other person, natural or otherwise; and lack of knowledge by any bidder shall not constitute a cognizable defense against the legal effect thereof.</p>

<p><b>EMPLOYMENT OF ALIEN WORKERS:</b> The College will comply with all aspects of Section 274A of the Immigration and Nationality Act. We will not knowingly engage with a company that does not adhere to these regulations and it is the obligation of the quoter to disclose any violation of such law to the College.</p>	<p><b>ASSIGNMENT:</b> Any Purchase Order issued pursuant to this RFQ invitation and the moneys which may become due hereunder are not assignable except with the prior written approval of the College.</p>
<p><b>CONTRACT:</b> The College will provide a contract subject to the terms and conditions of this RFQ. By bidding, the quoter agrees to these terms unless otherwise stipulated in writing and agreed upon by both parties.</p>	<p><b>AVAILABILITY OF FUNDS:</b> The obligations of the College under this award are subject to the availability of funds lawfully appropriated annually for its purposes by the Legislature of the State of Florida.</p>
<p><b>MANUFACTURERS' NAMES AND APPROVED EQUIVALENTS:</b> Any manufacturers' names, information and/or catalog numbers listed in a specification are for information and not intended to limit competition. The proposer may offer any brand for which he is an authorized representative, which meets or exceeds the specification for any items(s). If proposals are based on equivalent products, indicate on the proposal form the manufacturer's name and number. Proposer shall submit with his proposal, cuts, sketches, descriptive literature, and complete specifications. The bidder shall also explain in detail the reason(s) why the proposed equivalent will meet the specifications and not be considered an exception thereto. Reference to literature submitted with a previous bid will not satisfy this provision. Proposals that do not comply with these requirements are subject to rejection. Proposals lacking any written indication of intent to quote an alternate brand will be considered incomplete with the specifications as listed on the proposal form.</p>	<p><b>PUBLIC MEETING NOTIFICATION:</b> All meetings to judge and/or evaluate this solicitation or to make recommendations for award are held in strict compliance with Florida Statutes as they pertain to Florida in the Sunshine regulations. All meetings are fully open to all quoters as well as the public at-large.</p>
<p><b>INSPECTION, ACCEPTANCE AND TITLE:</b> Inspection and acceptance will be at destination unless otherwise provided. Title and risk of loss or damage to all items shall be the responsibility of the contract supplier until accepted by the College.</p>	<p><b>CONSORTIUM PURCHASE:</b> When an RFQ is issued on behalf of a consortium, prices shall be F.O.B., Ordering Institution address. Invoices shall be delivered to the Institution placing the order unless otherwise stated.</p>
<p><b>ADDENDA:</b> All addenda to this RFQ will be posted to the Palm Beach State College Purchasing web page containing the original solicitation. <a href="http://www.palmbeachstate.edu/purchasing.xml">www.palmbeachstate.edu/purchasing.xml</a></p>	<p><b>PRE-DECISION DISCUSSIONS:</b> Any discussion by the quoter with any employee or authorized representative of the College involving quote information occurring after the quotes are opened and prior to the posting of the recommended award will result in the rejection of that quote.</p>
<p><b>STATE LICENSING REQUIREMENT:</b> All entities defined under Chapters 607, 617 or 620, Florida Statutes, seeking to do business with the College shall be on file and in good standing with the State Of Florida's Department of State.</p>	<p><b>DISPUTES:</b> In case of any doubt or difference of opinion as to the specifications, equivalent products, or items to be furnished here under, the decision of the College shall be final and binding on both parties.</p>
<p><b>PUBLIC ENTITY CRIME INFORMATION STATEMENT:</b> All invitations to bid as defined by Section 287.012(11), Florida Statutes, requests for quotes as defined by Section 287.012(16), Florida Statutes, and any contract document described by Section 287.058, Florida Statutes, shall contain a statement informing persons of the provisions of paragraph (2)(a) of Section 287.133, Florida Statutes, which reads as follows: "A person or affiliate who has been placed on the convicted vendor list following a conviction for a public entity crime may not submit a bid on a contract to provide any goods or services to a public entity, may not submit a bid on a contract with a public entity for the construction or repair of a public building or public work, may not submit bids on leases of real property to a public entity, may not be awarded or perform work as a contractor, supplier, subcontractor, or consultant under a contract with any public entity, and may not transact business with any public entity in excess of the threshold amount provided in Section 287.017, for Category Two for a period of 36 months from the date of being placed on the convicted vendor list."</p>	<p><b>RETENTION OF RECORDS:</b> Contractor agrees to retain all client records, financial records, supporting documents, statistical records, and any other documents (including electronic storage media) pertaining to any contract resulting from this RFQ for a period of five (5) years. Copies of all records shall be made available to the College upon request. All invoices and documentation must be clear and legible for audit purposes. Documents must be retained by contractor within the State of Florida at an address to be provided, in writing, to the College within 30 days of the contract execution. Any records not available at the time of an audit will be deemed unavailable for audit purposes. The contractor will cooperate with the College to facilitate the duplication and transfer of any said records or documents during the required retention period. The contractor shall inform the College of the location of all records pertaining to the contract resulting from this RFQ and shall notify the College by certified mail within ten (10) days if/when the records have been moved to a new location.</p>
<p><b>ANTI-DISCRIMINATION CLAUSE:</b> The non-discrimination clause contained in Section 202, Executive Order 11246, as amended by Executive Order 11375, relative to Equal Employment Opportunity for all persons without regard to race, color, religion, sex or national origin, and the implementing rules and regulations provided by the Secretary of Labor are incorporated herein.</p>	<p><b>PROTEST:</b> "Failure to file a protest within the time prescribed in S. 120.57(3), Florida Statutes, or failure to post the bond or other security required by law within the time allowed for filing a bond shall constitute a waiver of proceedings under Chapter 120, Florida Statutes." All protests must be delivered to the Purchasing Manager within the time prescribed in Chapter 120, Florida Statutes to be considered valid.</p>
<p><b>DISCRIMINATORY VENDOR'S LIST:</b> Any entity or affiliate who has been placed on the Discriminatory Vendors List may not submit a quote to provide goods or services to a public entity, may not be awarded a contract or perform work as a contractor, supplier, subcontractor, or consultant under contract with any public entity and may not transact business with any public entity.</p>	<p><b>AMERICANS WITH DISABILITIES ACT:</b> The contractor shall comply with the Americans with Disabilities Act. In the event of the contractor's non-compliance with the non-discrimination clauses of the Americans with Disabilities Act, or with any other such rules, regulations or orders, any contract resulting from this RFQ may be cancelled, terminated or suspended in whole or in part and the contractor may be declared ineligible for further contracts</p>
<p><b>SUBCONTRACTORS:</b> The quoter is fully responsible for all work performed under the Contract resulting from this RFQ. The quoter may, upon receiving prior written consent from the College's Purchasing Manager, enter into written subcontract(s) for performance of certain of its functions under the Contract. No</p>	<p><b>REJECTION OF QUOTES:</b> The College may reject any and all quotes not meeting mandatory responsiveness requirements, which include terms, conditions or requirements that must be met by the quoter to be responsive to this RFQ. These responsiveness requirements are mandatory. Failure to meet these</p>

<p>subcontract, which the quoter enters into with respect to performance of any of its functions under the Contract, shall in any way relieve the quoter of any responsibility for the performance of its duties, including any and all liabilities that may arise out of the subcontractor's work related to the project. All payments to subcontractors shall be made by the quoter.</p>	<p>responsiveness requirements will cause rejection of the quote. In addition, the College may reject any or all quotes containing material deviations. Any bid rejected for failure to meet mandatory responsiveness requirements will not be reviewed.</p>
<p><b>INSURANCE REQUIREMENTS:</b> When performing a service, construction work or any type of installation is required on College property, the successful vendor is required to supply a Certificate of Insurance evidencing coverage during the period the vendor is providing services per the following:</p> <ol style="list-style-type: none"> <li>1. Workers compensation and employee's liability in accordance with the laws of the State of Florida.</li> <li>2. Bodily injury liability, minimum of \$1,000,000 per person and \$1,000,000 per accident.</li> <li>3. Property damage liability, minimum of \$1,000,000 per occurrence and \$2,000,000 aggregate.</li> <li>4. Umbrella liability with limits of not less than \$1,000,000 per occurrence and \$2,000,000 aggregate.</li> <li>5. Contingent coverage for sub-contractors for liability at the site.</li> </ol> <p>The bidder must list any sub-contractor that will perform work under this bid. The Certificate of Insurance must be provided to the College prior to the commencement of any work.</p>	<p><b>QUOTE INQUIRIES:</b> The quoter may examine this RFQ to determine if the College's requirements are clearly stated. If there are any requirements that restrict competition, the quoter may request, in writing, to the College that the specifications be changed. The quoter that requests changes to the College's specifications must identify and describe the quoter's difficulty in meeting the specifications, must provide detailed justification for a change, and must recommend changes to the specifications. Proposer's failure to request changes shall be considered to constitute quoter's acceptance of the specifications. The College shall determine what changes to this RFQ shall be acceptable to the College. If required, the College shall issue an addendum reflecting the acceptable changes to this RFQ, which shall be available to all quoters in order that all quoters shall be given the opportunity of proposing to the same specifications</p>
<p><b>VERBAL INSTRUCTIONS:</b> No negotiations, decisions, or actions shall be initiated or executed by the quoter as a result of any discussions with any College employee. Only those communications that are in writing from the College's Purchasing staff identified in this RFQ shall be considered a duly authorized expression on behalf of the College. Only communications from the quoter's representative that are in writing and signed will be recognized by the College as duly authorized expressions on behalf of the quoter.</p>	<p><b>TERMINATION AT WILL:</b> The Contract resulting from this RFQ may be terminated by either party upon no less than thirty (30) calendar days' notice, without cause, unless a lesser time is mutually agreed upon by both parties. Notice shall be delivered by certified mail (return receipt requested), by other method of delivery whereby an original signature is obtained, or in-person with proof of delivery</p>
<p><b>INCLUSION OF SUPPORTING DOCUMENTS:</b> All those submitting sealed replies in response to this Request for Quotes understand that the RFQ document, the sealed reply, and all documents and/or materials represented in presentation to the committee shall be a complete record and shall be included in the final contract.</p>	<p><b>PROPOSED RULES FOR WITHDRAWAL:</b> A submitted quote may be withdrawn by submitting a written request for its withdrawal to the College, signed by the quoter/contractor, prior to the bid opening date.</p>
<p><b>FORCE MAJEURE:</b> Neither party shall be liable for loss or damage suffered as a result of any delay or failure in performance under the Contract resulting from this RFQ or interruption of performance resulting directly or indirectly from acts of God, accidents, fire, explosions, earthquakes, floods, water, wind, lightning, civil or military authority, acts of public enemy, war, riots, civil disturbances, insurrections, strikes, or labor disputes.</p>	<p><b>SUBSTITUTION OF KEY PERSONNEL:</b> In the event the successful quoter desires to substitute any key personnel submitted with his/her quote, either permanently or temporarily, the College shall have the right to approve or disapprove the desired personnel change in advance in writing.</p>

**STANDARD TERMS AND CONDITIONS**

<p><b>Amendments:</b> Palm Beach State College reserves the right to amend this RFQ prior to the quote due date. All amendments and additional information will be posted to the Palm Beach State College Purchasing Web site: <a href="http://www.palmbeachstate.edu/purchasing.xml">www.palmbeachstate.edu/purchasing.xml</a> Quoters should check this Web page daily for new information.</p>	<p><b>Contract Discussions:</b> Prior to award, the apparent successful firm may be required to enter into discussions with the College to negotiate the contract agreement for services. These discussions are to be finalized and all exceptions resolved within one (1) week from notification. If no resolution is reached, the quote may be rejected and discussions initiated with the next highest scoring firm.</p>
<p><b>Confidentiality Requirements:</b> Quotes are subject to the Florida public records laws. The College cannot protect proprietary data submitted in quotes.</p>	<p><b>Financial Information</b> The quoter will submit an audited financial statement for the most recent 12-month period. As a minimum, the audited financial statement shall consist of the firm's balance sheet and statement of operations and the firm's bonding capacity. This financial requirement may be satisfied by the firm's surety submitting a certification regarding the firm's bonding capacity, which must equal or exceed \$1 million dollars. In this regard, the firm's surety must be a licensed surety qualified to conduct business in the State of Florida and rated "(A-)" or better in the most recent A.M. Best Guide and qualified to do business within the State.</p>

# Section B

## SCOPE OF SERVICES AND REQUIREMENTS

**B1. PROJECT SUMMARY**

Palm Beach State College is requesting quotes for Theatre Lighting.

**B2. SCHEDULE:** This request for a quote will be governed by the following schedule:

Release of RFQ	December 7, 2011
Deadline for Written Questions	January 6, 2012
Answers to Questions posted on Palm Beach State College Purchasing website <a href="http://www.palmbeachstate.edu/purchasing.xml">www.palmbeachstate.edu/purchasing.xml</a>	January 13, 2012
Quotes Due	January 23, 2012
Evaluation/screening of quotes	January 24, 2012 – January 27, 2012
Award date	January 30, 2012

**B3. CONTRACT TERM:** None, this is a single procurement.

**B4. PROJECT STATEMENT OF WORK**

**Requirements**

- Vendor will submit a brief overview of the company's history and sufficient data to support that the company is financially capable of handling the project as outlined. Vendor shall also disclose any and all litigations closed or pending within the last five (5) years and any contract terminations.
- Vendor will provide at least three (3) references. These references shall include clients with similar projects. Give client's name, project name, contact name, contact telephone number and contact email address.
- Vendor to submit qualification of installation & project staff members for this project, including certificates.
- Vendor will submit complete pricing information with proposal.

# Section C

## INSTRUCTIONS AND INFORMATION

### C1. PROCESS FOR SUBMITTING QUOTES

#### a) Packaging of Quote

The quote must be plainly identified as:

Name of Proposing Company

**RFQ Number: 11/12-06**

**Due: no later than 3:00 p.m.**

Palm Beach State College MS 27

4200 Congress Avenue

Lake Worth, FL. 33461

Outer mailing boxes, envelopes, containers, etc., must display the RFQ number. This includes outer carrier boxes and labels. Palm Beach State College will not be held responsible for quotes that are misdirected or mishandled because of the omission of this number.

Any additional information sent separately from the quote package or at a later date (i.e. addendums, clarifications, quote withdrawal requests, etc.) must be received by the quote due date and the RFQ number clearly identified on the outside of the package.

#### b) Number of Quote Copies

Submit an original and 1 PDF copy on a USB drive.

#### Each submission must contain the following separated labeled tabbed dividers:

- (a) Submission Response Form
- (b) Professional Certification/Licenses
- (c) Company Overview
- (d) Comparable Sample
- (e) References
- (f) Price
- (g) Listing of Equipment

### C2. EVALUATION CRITERIA

The evaluation of quotes received on time will be conducted in the following two phases:

#### a) Administrative Review Phase

The quotes will be reviewed for the following administrative requirements:

Quote was submitted by the due date and time

1. All documents (originals and copies) requiring a signature have been signed
2. Correct number of quote copies have been submitted
3. The quote that passes the administrative review will be reviewed for completeness to ensure that all mandatory requirements are addressed satisfactorily in Appendix A.

Failure to adhere to the above administrative requirements may result in the rejection of the submitted quote.

**b) Quality Review Phase**

The proposals that pass the requirements review will be reviewed for quality and completeness and can receive a maximum of 100 points. The following listing provides you with the maximum points available for each factor in the evaluation:

- (a) Company Overview – 10 points
- (b) Company References – 20 points
- (c) Staff Qualifications - 30
- (d) Cost – 40 points

# Appendix A

## SUBMISSION RESPONSE FORM

Purchasing Department  
 Palm Beach State College  
 4200 Congress Avenue MS#27  
 Lake Worth, FL 33461

This is to certify that I (authorized representative) have read and understood the terms, conditions, specifications and other instructions contained in this Request, and further, that the items of materials and/or services rendered do meet minimum specifications set forth in this Invitation.

I further certify that this quote is made without prior understanding, agreement, or connection with any corporation, firm, or persons submitting a quote for the same materials, supplies, or equipment and is in all respect fair and without collusion or fraud. I agree to abide by all conditions of this request and certify that I am authorized to sign this quote for the bidder.

<b>RFQ</b>	<b>11/12-06</b>	<b>Theatre Lighting</b>
------------	-----------------	-------------------------

<b>Vendor Name</b>	
--------------------	--

<b>Bidding As (check one)</b>	<b>Corporation</b>		<b>Individual</b>		<b>Other (explain)</b>	
-----------------------------------	--------------------	--	-------------------	--	----------------------------	--

<b>Address</b>	
----------------	--

<b>City</b>		<b>State</b>		<b>Zip Code</b>	
-------------	--	--------------	--	-----------------	--

<b>Telephone</b>		<b>Fax</b>	
------------------	--	------------	--

<b>E-Mail</b>	
---------------	--

<b>Representative Title</b>	
-----------------------------	--

<b>Signature</b>	
------------------	--

# Appendix B

## PROJECT SPECIFIC BACKGROUND

**Purpose**

Palm Beach State College is soliciting bids for a qualified vendor to provide the equipment, supplies and installation labor for lighting equipment at our Eissey Campus Theatre. Due to some customized work all participating bidders must make an appointment with the Theatre’s Technical Staff to have full knowledge of the scope of work.

**Project Expectations**

- It is the bidder’s responsibility to become fully informed as to the nature and extent of the work required.
- It is recommended the bidder’s make a site visit. The project’s contact is the Theatre Technical Staff, Bob Woods, [woods@palmbeachstate.edu](mailto:woods@palmbeachstate.edu), OFC: (561)207-5905 or CELL: (561)236-4116.
- Campus Location: [3160 PGA Blvd., Bldg AU, Palm Beach Gardens, FL 33410](#)
- Vendor will be responsible to fully set up and install, operate and demonstrate use of equipment at time of delivery to college personnel.
- Installation: Installation to include the removal of original 4<sup>th</sup> electric batten and the rehang of the new moving head truss and raceway with all custom brackets and hardware.

**Pricing**

**EQUIPMENT:**

- |    |         |   |                            |
|----|---------|---|----------------------------|
| 1) | 12 each | Fixtures, Martin 90231400 MAC-350 Entour LED lighting<br>Brand: _____ Product # _____ |                            |
|    |         | Unit Price: \$ _____  | Extended Price: \$ _____   |
| 2) | 5 each  | Truss, Thomas 12X12X10’ black with bolts<br>Brand: _____ Product # _____              |                            |
|    |         | Unit Price: \$ _____  | Extended Price: \$ _____   |
| 3) | 1 each  | Truss, Thomas 12X12X3’ black with bolts<br>Brand: _____ Product # _____               |                            |
|    |         | Unit Price: \$ _____  | Extended Price: \$ _____   |
| 4) | 1 lot   | Installation of equipment<br>Unit Price: \$ _____                                     | Extended Price: \$ _____   |
|    |         |   | <b>BID TOTAL: \$ _____</b> |

**WARRANTY:**

- 5) Statement of Equipment Warranty: \_\_\_\_\_  
\_\_\_\_\_
- 6) Statement of Workmanship Warranty: \_\_\_\_\_  
\_\_\_\_\_

# Unrivaled hard-edge LED moving head

The **MAC 350 Entour** is a cutting-edge LED profile fixture with no peers. It surpasses what has previously been possible in terms of brightness, efficiency and compactness in a hard-edge LED fixture.

Featuring proprietary LED technology, it is the market's first real alternative to traditional HID-based profile fixtures.



- 8000 lm output via 7 high power LEDs
- Brighter than 300 watt HID fixtures and no lamp replacements
- Compact and light
- Enhanced color rendition and spectrum
- Full electronic dimming
- Excellent projection quality
- Totally flicker-free and quiet
- Energy and cost savings

## Specifications Preliminary Data

### Physical

Length: 387 mm (15.2 in.) including handles  
 Width (Base): 220 mm (8.7 in.)  
 Height: 454 mm (17.9 in.), head horizontal  
 Height: 471 mm (18.5 in.), head straight up  
 Weight: 16 kg (35.3 lbs.)

### Dynamic Effects

Color wheel: 8 interchangeable dichroic filters  
 + open, full and split colors, music trig, continuous rotation, random color  
 Rotating gobo wheel: 6 interchangeable gobos + open, indexing, continuous gobo rotation & scrolling, shake  
 Iris: Motorized  
 Electronic dimming: 0 - 100%, choice of four dimming curves  
 Strobe effect: Electronic, with pulse and random effects  
 Focus: 2 m (6.6 ft.) to infinity  
 Pan: 540°  
 Tilt: 257°  
 Adjustable pan/tilt and effects speed

### Optics

Light source: 7 x 50 W LEDs  
 Minimum LED lifetime: 60 000 hours (70% maintenance)

### Control and Programming

Control options: DMX, stand-alone, synchronized (master/slave)  
 DMX channels: 12/15  
 Setting and addressing: Control panel with LED display  
 Macro programs: 10 pan/tilt and 10 effects macros, all with staggered start/chase feature

Macro selection: DMX or onboard control panel  
 Movement control options: Tracking and vector  
 Protocol: USITT DMX512/1990  
 Stand-alone memory: 100 scenes  
 Stand-alone and master/slave programming: Control panel with LED display  
 Transceiver: RS-485  
 Fixture software update: Serial upload via DMX link  
 16-bit control: Rotating gobo indexing, pan & tilt

### Photometric Data

Total output: 8000 lm  
 CRI (color rendering index): 70  
 Efficiency: 55%  
 Efficacy: 18.6 lumens per watt  
 Color temperature: 6500 K

### Construction

Color: Black  
 Housing: UV-resistant fiber-reinforced composite and die-cast aluminum  
 Protection rating: IP20  
 Installation Mounting points: 2 pairs of 1/4-turn locks  
 Orientation: Any  
 Connections AC power input: Neutrik PowerCon  
 DMX data in/out: 5-pin locking XLR

### Electrical

AC power: 100-130/200-240 V nominal, 50/60 Hz  
 Maximum total power consumption: 430 W  
 Power supply unit: Auto-ranging electronic switch mode  
 Main fuses: 10 AT (slow blow) x 2  
 Standby power: 18 W (idle mode, dimmed to zero)

### Thermal

Cooling: Forced air (temperature-regulated, low noise,

user-definable levels)

Max. ambient temperature (Ta max.): 40° C (104° F)  
 Maximum surface temperature, steady state, Ta=40° C (104° F): 120° C (248° F)  
 Total heat dissipation (calculated, +/- 10%): 1470 BTU/hr.

### Approvals

EU safety: EN 60598-1, EN 60598-2-17  
 EU EMC: EN 61000-3-2, EN 61000-3-3, EN 61000-6-2, EN 61000-6-4  
 US safety (US model), pending: UL 1573  
 Canadian safety (US model), pending:  
 CSA C22.2 No. 166  
 Australia/NZ: C-TICK N4241

### Included Items

Two Omega clamp attachment brackets with 1/4-turn fasteners: P/N 91602001  
 User manual

### Accessories

G-clamp: P/N 91602003  
 Half-coupler clamp: P/N 91602005  
 Quick trigger clamp: P/N 91602007  
 T-shaped omega bracket with quarter-turn fasteners: P/N 91602008  
 Omega bracket: P/N 91602001  
 Safety wire, universal, safe working load 50 kg (110.2 lbs.): P/N 91604003  
 Two-unit flightcase for 2 x MAC 350

### Ordering Information

MAC 350 Entour, black, in cardboard box:  
 P/N 90231400

### Martin Professional A/S

Olof Palmes Allé 18 | 8200 Aarhus N | Denmark | Phone: +45 87 40 00 00 | Fax: +45 87 40 00 10 | www.martin.com

Founded in 1986 and headquartered in Aarhus, Denmark, Martin Professional is a world leader in the creation of dynamic lighting solutions for the entertainment, architectural, and commercial sectors. Martin lighting solutions are industry standard on top tours and events, grace prestigious theatres, energize nightclubs, and decorate major television studios around the globe. The company operates the industry's most complete and capable distributor network with local partners in nearly 100 countries. For more information please visit www.martin.com

© 2010 Martin Professional A/S | Images contained in this brochure have been converted to CMYK and are not necessarily representative of actual colors. | Specifications are subject to change without notice



# GP 12 x 12

12" x 12" General Purpose truss is manufactured from 2" dia x 0.125" wall and 1" dia x 0.125" wall 6082T6 or 6061T6 Aluminium tubing. Bolts are supplied for assembly of truss elements. This truss is ideal for conference, exhibition, and small venue work. By incorporating suitable sleeve blocks and towers, this truss can be used with our Ground Support System.

PRODUCT CODE	DESCRIPTION	WT lbs
B0700	10' Section	55
B0701	8' Section	46
B0702	5' Section	35
B0703	2' 6" Section	24
B4700	3m Section	55
B4701	2.5m Section	46.5
B4702	2m Section	40.5
B4703	1.5m Section	35
B4704	1m Section	19.5
B4705	2 Way Corner Block	15
B4705A	3 Way Corner Block	17.5
B4706	4 Way Corner Block	19.5
B4707	6 Way Corner Block	26.5
B4708	Flat Plate Hinge Section	14

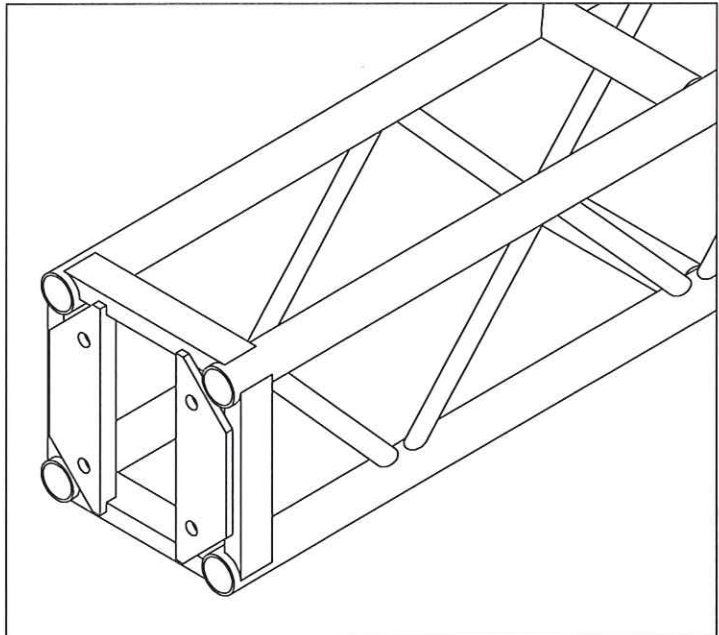

Span feet (meters)	Maximum Allowable Uniform Loads		Maximum Allowable Center Point Loads	
	Loads pounds (kgs)	Maximum deflection inches (mm)	Loads pounds (kgs)	Maximum deflection inches (mm)
10 (3.048)	6140 (2785)	0.276 (7)	4497 (2040)	0.315 (8)
20 (6.096)	3100 (1406)	1.10 (28)	1550 (703)	1.10 (28)
30 (9.144)	1726 (783)	2.21 (56)	864 (392)	2.21 (56)
40 (12.192)	855 (388)	2.96 (75)	428 (194)	2.96 (75)

LOADING FIGURES show maximum loads between supports in addition to the self weight of the truss. Information extracted from the structural report by Broadhurst, Goodwin, and Dunn suit maximum shear capacity. All loads include 20% overload factor for dynamic effects.

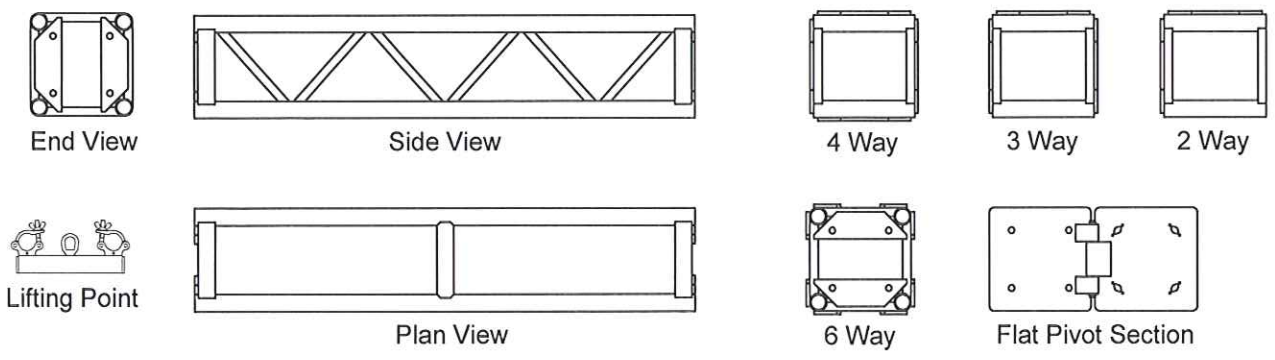

# Appendix C

## FORM FOR SUBMITTING WRITTEN QUESTIONS

---

Written Questions for RFQ No.	11/12-06
RFQ Title	Theatre Lighting
Company Name	
Date	
Deadline for Questions	

Type your questions in the section below. Leave the answer section blank. You are not limited to 10 questions. All questions should be sent via email to: [purchasing@palmbeachstate.edu](mailto:purchasing@palmbeachstate.edu) before the deadline.

	Questions	Answers [leave blank]
1		
2		
3		
4		
5		
6		
7		
8		
9		
10		

# Appendix D

## STATEMENT OF NO BID

RFQ No.	11/12-06
RFQ Title	Theatre Lighting

Palm Beach State College  
Purchasing Department  
4200 Congress Avenue MS#27  
Lake Worth, FL 33461

Attn: Purchasing Manager

We, the undersigned, have declined to bid on your bid number **11/12-06** for a(n) **Theatre Lighting** for the following reason(s):

\_\_\_\_\_ We do not offer this product / service.

\_\_\_\_\_ Our current workload would not afford us the time to devote to your project.

\_\_\_\_\_ Unable to meet specifications.

\_\_\_\_\_ Unable to meet insurance / bond requirements.

We understand that if the "No Bid" is not executed and returned that our name may be removed from the list of qualified bidders for Palm Beach State College.

Company Name \_\_\_\_\_

Signature \_\_\_\_\_

Company Address \_\_\_\_\_

Telephone Number \_\_\_\_\_